

Kestrel Autopilot v2.4

New Features –

- Dual Ported Pressure sensor.
- Improved gimbal support (position, flashlight)

2" x 1.37" x .47"
21 grams

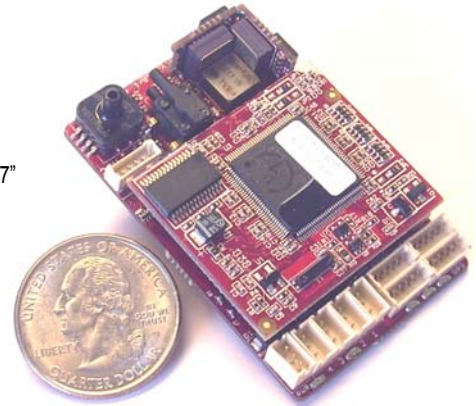

FEATURES

- 3-Axis Angular Rate & Acceleration Measurement.
- Magnetometer (2 and 3-Axis).
- 20 Point Sensor Temperature Compensation.
- External Power @ 3.3V & 5V, 500mA.
- Efficient Switching Power Regulation.
- Battery Voltage and Current Monitor.
- 29MHz Processor w/ 512K RAM & FLASH.
- 4 Serial Ports (Std., SPI, I²C) w/ Digital Clock or I/O.
- 4 Onboard Servo Ports, 8 External Servo Ports.
- Flapperon, v-tail, elevon, ruddervator, custom servo mixing.
- 12 Digital I/O (6 bi-directional, 3 input, 3 output).
- 3 Analog Inputs @ 12bit resolution.
- Optional Piggy-Back Modem Header.
- Wind Estimation – good to 5% on speed & 2% on heading.
- Auto-trim.
- Multiple Failsafes including LOL, Loss of GPS, Low Battery, and Collision with Terrain. (uses terrain elevation data)
- Multi-UAV and Convoy Following Support.
- GPS-denied operation – gracefully handles GPS outages using dead-reckoning filter.
- Altitude can be referenced to sea level and can be initialized using onboard GPS, Ground GPS, or entered manually.
- Configurable IO support, including modem-mirror and serial pass-through to allow easy interface to external CPU or payload.
- Smart loiters
 - Camera Centric – Geo-locates center pixel of fixed or gimballed camera FOV and initiates loiter around that point.
 - With fixed camera, autopilot calculates optimal loiter radius and eccentricity based on wind and altitude to keep geo-located target in camera FOV.
 - If gimbal is present, autopilot will stabilize gimbal and point at geo-located target.
- Selectable units (Metric, English, Nautical).
- Absolute vs relative waypoints (legal waypoints).
- Robust built-in support for 2-axis gimbal with zoom.
- RSSI using Maxstream modems.

APPLICATIONS

- Autonomous GPS navigation of small UAVs and MAVs
- Multiple vehicle operations
- Inertial Measure Unit
- Slave Processing Unit and Data logger
- Payload Communication & Control Support

DESCRIPTION

The Kestrel™ Autopilot v2.4 is designed for autonomous flight control of small UAVs and MAVs. At 16.7 grams, it is the smallest (2" x 1.37" x .47") and lightest full-featured autopilot on the market - ideal for all surveillance and reconnaissance applications. The Virtual Cockpit ground control software makes "click N' fly" operation easy while providing powerful mission planning, monitoring, and in-flight adjustment. New "piggy-back" header allows the modem to be plugged directly into the autopilot. The magnetometer can either be on board the autopilot or off board.

Its IMU is composed of 3-axis rate gyros and accelerometers. Absolute and differential pressure sensors provide barometric pressure and aircraft air speed. 3 temperature sensors combined with a 20 point temperature compensation algorithm reduce sensor drift improving aircraft state measurement and estimation.

Switching power regulation achieves high efficiency, drawing only 0.77 Watts while running cooler and consuming less power. External payloads can be powered at 3.3V and 5V, 500mA each. Battery voltage and current monitoring provides battery life information.

4 serial ports allow for support of payload inter-communication and control. Serial interfaces allow for the use of standard off-the-shelf digital modems and GPS units. External servo board supported for additional servo output.

➤ Kestrel, Virtual Cockpit, & OnPoint Targeting are trademarks of Procerus® Technologies. ©2004 - 2010. All Rights Reserved.

Kestrel Autopilot v2.4

Smart Loiters (fixed and gimbal cameras)

Using gimbal cameras and forward or side look fixed cameras the user can center an object / target in their field of view and click "loiter now". The Kestrel will geo-locate the target and place a loiter point at that location and direct the UAV to it. The Kestrel then calculates the optimal radius and eccentricity to keep the object in the center of the FOV. If a gimbal is present, the autopilot will stabilize the camera and keep the gimbal pointed at the target.

GPS Targeting with Gimbal

Users can instruct the autopilot to "target gimbal here" on the map. A cross hair is placed on the target - the gimbal remains locked on. Click-n-drag the cross hair to new targets as desired. The gimbal follows & locks on independent of flight path. Terrain elevation data utilized for greater accuracy. The gimbal can also be used to geo-locate objects with a single click.

Vision-based Target Localization

Vision-based target localization allows the user to obtain GPS coordinates of desired ground targets to within 5m or less. Terrain Elevation Data is utilized to maximize accuracy. Users can [click in the video](#) on a desired target and the autopilot will fly the UAV to the object and loiter about it - within 1 revolution GPS coordinates will be given to within 5m accuracy. If the target moves, the user can repeatedly click on the moving target and the UAV will follow, providing GPS coordinates as it does so.

External Processor Support

The Kestrel Autopilot has a built in ability to listen to two different modems or serial connections at the same time.

Mode support - single click autopilot configurations

Mode	Behavior
Manual	Rates only, activated by switch on RC controller
Speed	Aircraft holds airspeed using pitch, (roll, airspeed, and throttle commands on ground station)
Altitude	Aircraft holds altitude (roll, airspeed, and altitude commands from on ground station)
Navigation (Nav)	Aircraft navigates to standard and loiter waypoints
Home	Aircraft flies home and loiters
Loiter Now	Aircraft loiters at current position
Take Off (3)	Aircraft uses preset commands to take off - automatically transitions to Nav mode at pre-set altitude
Land	Aircraft flies to landing point on map and lands
Rally	Aircraft flies to Rally point

Multiple User-Configurable Failsafes

- Loss of communications.
- Loss of GPS lock.
- Low Battery and Critical Battery.
- Loss of communication during RC Mode.
- Flight Termination.
- Terrain Elevation Data – height above ground failsafe using elevation data.

Gimbal Support:

- Autopilot optimized gimbal loiters. (point / click - Kestrel computes radius)
- Terrain Elevation Data is used for gimbal pointing accuracy.
- Gimbal Mode status display in Artificial Horizon.
- Gimbal position indicators on-screen.
- "Flashlight" view on map to aid user.
- Gimbal multi-point setup and configuration screen.
- Smooth panning with hand controller.
- Change gimbal mode with gamepad.
- Click-n-drag crosshair – gimbal follows and locks on target.



Procerus partner, Brandebury Tool, is the maker of the small gimbal shown above. (360 degree, 76 grams) 2.75" high (including ball) x 1.5" Wide x 3.5" Long



Gumstix processor connected to the Kestrel.

Kestrel Autopilot System

ABSOLUTE MAXIMUM RATINGS

Input Supply Voltage	-0.3V to 16.5V
Input Supply Voltage (Kestrel v2.4).....	-0.3V to 24V
Payload Current (including modem).....	1.5A @ 3.3V
Operating Temperature Range	-40°C to 85°C
Storage Temperature Range.....	-40°C to 125°C
Maximum Absolute Pressure.....	400 kPa
Maximum Differential Pressure	75kPa
Humidity	5% to 95%, no condensing
Acceleration	±200 g

Stresses above those listed under the Absolute Maximum Ratings may cause permanent damage to the autopilot. This is a stress rating only; functional operation of the device at these or any other conditions above those indicated in the operational section of this specification are not implied. Exposure to absolute maximum rating conditions for extended periods may affect device reliability.

OPERATING CHARACTERISTICS

Parameter	Conditions	Min	Typ	Max	Units
Power (PWR)					
Input Voltage Range (Vin)		6.0		16.5	V
Input Voltage Range (Vin) v2.23 and later		6.0		24	V
Quiescent Supply Current	Vin @ 12V		70		mA
Operating Power (no modem)			0.8		W
Operating Power (with Modem)	Maxstream 9Xtend modem		1.2	4.8	W
Max Modem Power @ 3.3V	(max 1.25A @ 3.3V)			4	W
Payload POWER (Each Supply)					
3.3V Source			3.3	≈2.0	W
5V Source			5.0		V
Supply Current (including modem)	@ 3.3V			1.25	A
Accuracy			±0.5	±2	%
Noise (Pk-Pk Ripple)			15		mV _{RMS}
Analog Input Port					
5V Supply (Vs) Current	Vs = 4.95 V		50		mA
5V Supply (Vs) Noise			2.5		mV _{RMS}
ADC Input Sample Range		0		5	V
ADC Input Sample Resolution	Vs = 5 V		16 (0.0763)		bits (mV)
ADC Input Impedance			194K		Ω
Payload Serial & I/O					
Logic High		2.3			V
Logic Low				0.4	V
Current (Sink & Source)				6.8	mA
Rate Gyros					
Dynamic Range	TA = 25°C, VS = 5 V, Bandwidth = 9Hz			±300	°/s
Frequency Response (3dB Bandwidth)			9		Hz
Resonant Frequency			14		kHz
Resolution			0.0318		°/LSB
Noise Density			0.1		°/sec/√Hz
Accelerometers					
Dynamic Range	TA = 25°C, VS = 5 V			±10	g
Frequency Response (3dB Bandwidth)			22		Hz
Resonant Frequency			10		kHz
Resolution			0.00150		g/LSB
Noise Density			200		μg/√Hz rms
Attitude Estimation Error: Roll and Pitch					
Level Flight				5	°
During Turns				10	°
Differential Pressure: KAPv2.20, KAPv2.21					
Range	TA = 25°C, VS = 5 V	-0.25		4.7	kPa
Resolution			0.000166		kPa
Differential Pressure: KAPv2.22 to KAPv2.4					
Range	TA = 25°C, VS = 5 V	-1.3		15.8	kPa
Resolution			0.000545		kPa
Absolute Pressure: KAPv2.20, KAPv2.21					
Range	TA = 25°C, VS = 5 V	101.5		66.5	kPa
Resolution			0.00115		kPa
Absolute Pressure: KAPv2.22 to KAPv2.4					
Range	TA = 25°C, VS = 5 V	111.3		41.5	kPa
Resolution			0.00244		kPa
Drift from Delta Temperature	16°C Range		0.00175	0.00584	kPa/°C
Airspeed: KAPv2.20, KAPv2.21					
Range	TA = 25°C, VS = 5 V	0		70 (156)	m/s (mph)
Resolution			0.0076 (0.017)		m/s (mph)
Airspeed: KAPv2.22 to KAPv2.4					
Range	TA = 25°C, VS = 5 V	0		130 (290)	m/s (mph)
Resolution			0.025 (0.056)		m/s (mph)



Kestrel Autopilot System

Altitude: KAPv2.20, KAPv2.21 Range Resolution	$T_A = 25^\circ\text{C}$, $V_S = 5\text{V}$ Standard atmospheric pressure	-13.7 (-45)	0.116 (0.379)	3414 (11,200)	m (ft) m (ft)
Altitude: KAPv2.22 to KAPv2.4 Range Resolution Drift from Delta Temperature	$T_A = 25^\circ\text{C}$, $V_S = 5\text{V}$ Standard atmospheric pressure	-792 (-2,600)	0.245 (0.804) 0.188 (0.615)	6,888 (22,600)	m (ft) m (ft) m ² C (ft ² C)
Dimensions Accuracy			2.073 x 1.375 ± 0.5		inches %
Weight Accuracy			16.65 ± 4		grams %

PORT FUNCTIONS

The following tables describe the general pin assignments for each port type.

Power Port

Pin	Description
1	GND
2	PWR (6V – 18V)
3	Current Monitor

Servo Ports

Pin	Description
1	PWR
2	GND
3	Signal

Optional ADC Port

Pin	Description
1	GND
2	PWR (3.3V or 5V)
3	Ch 1
4	Ch 2
5	Ch 3

Serial Ports

Pin	Description
1	GND
2	PWR (3.3V or 5V)
3	Autopilot TX
4	Autopilot RX
5	CMD or CLK

Power Port: This port supplies the autopilot power and is typically connected directly to the autopilot or aircraft main battery. The GND and PWR pins connect to the negative and positive battery terminal respectively. The Current Monitor pin is used to detect current draw of the main battery by measuring the voltage drop across a 0.01Ω resistor in series with the battery. This resistor's power rating should be as follows:

$$\text{RESISTOR POWER} > (\text{MAX MOTOR CURRENT})^2 \times 0.01 \text{ (WATTS)}$$

Typical Current Monitor Circuit:

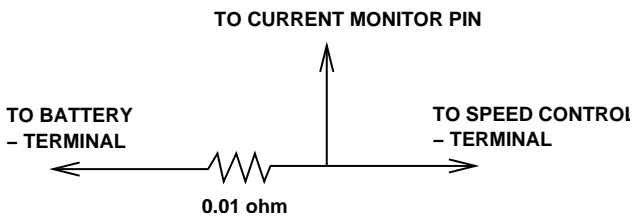

Analog Input Port: Three analog inputs (pins 3-5) on the Analog Input port allow users to measure 0.0V to 5.0V. Filtered analog 5V supply is available on pin 2. This pin supplies the autopilot analog sensors so take caution not to introduce noise on this pin. For specifications, see Analog Input Port in the Operating Characteristics table.

Serial & I/O Ports: There are 4 serial ports that double as I/O ports. Serial E and Serial A allow users to interface with

payload needs. The GPS port is dedicated for the GPS unit. The MODEM port is optional if the modem is not plugged into the modem "piggy-back" header. For each serial port, the autopilot TX and RX lines are found on pins 3 and 4 respectively. All serial ports operate at TTL levels (0V to 3.3V) and can be configured for standard serial, SPI, or I²C communication. Pin 5 on all serial ports serves as a digital I/O. Pins 2 and 3 can be used as digital I/O if not being used for serial communication. Table 1 shows the pin assignments (connections to Rabbit 3000 processor) of all serial ports.

Pin	SerA	SerE	GPS	Modem
1	GND	GND	GND	GND
2	PWR (3.3V or 5V)	PWR (3.3V or 5V)	PWR (3.3V or 5V)	PWR (3.3V or 5V)
3	TxA (PC6)	TxE (PG6)	TxD (PC0)	TxF (PG2)
4	RxA (PC7)	RxE (PG7)	RxD (PC1)	RxF (PG3)
5	Reset/Smode	ClkE (PG5)	ClkD (PF0)	TCIkF (PG0)

Table 1 - Serial Port Pin Descriptions

Servo Ports: These ports are configurable for different aircraft types. Servo connections for standard configurations are as follows:

V-Tail Configuration

Port	Channel
1	Right V-Tail
2	Left V-Tail
3	Throttle

Elevon Configuration

Port	Channel
1	Left Elevon
2	Right Elevon
3	Throttle

Kestrel Autopilot System

KESTREL AUTOPILOT

The autopilot is the heart of the Kestrel system. It is powered by an 8-bit 29 MHz processor. The autopilot board contains a suite of sensors used by the autopilot software to measure and estimate the states of the aircraft. The autopilot interfaces directly to the digital communication link which enables it to send real-time status telemetry to the ground station and receive commands in-flight. The GPS plugs into the autopilot board (optional) and provides inertial navigation information to the autopilot. It also has several additional interface ports to support payloads. The autopilot controls the aircraft through four standard RC hobby servos. If more servos are needed, a servo extender board can be used. Figure 1 shows the Kestrel autopilot with modem attached.

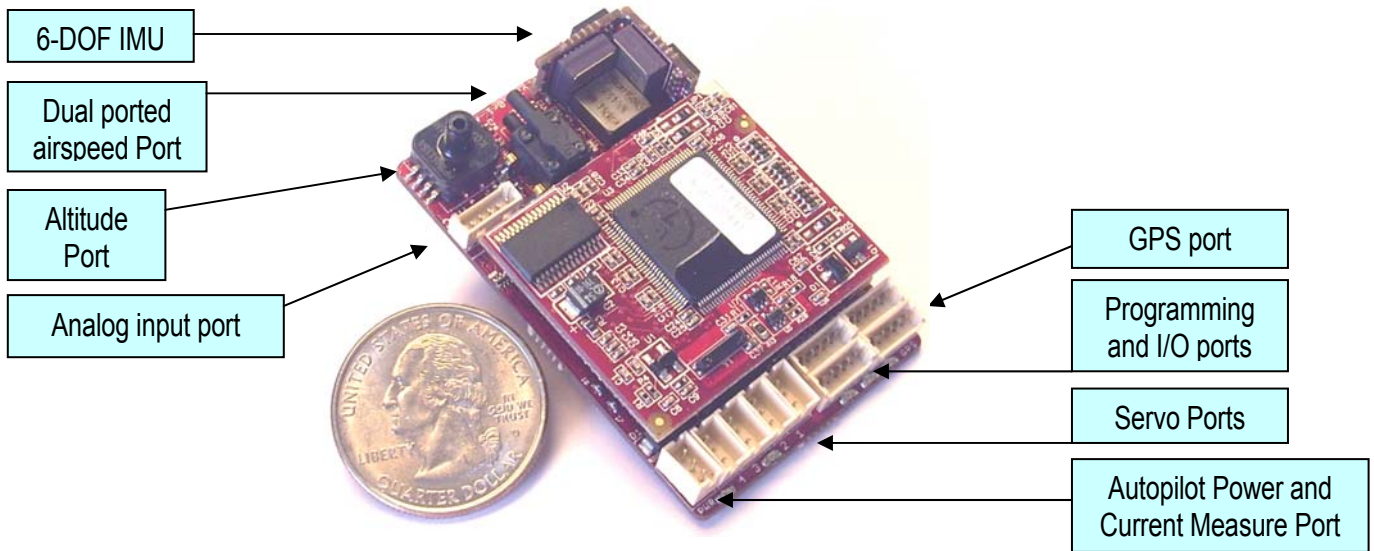

Figure 1 - Kestrel 2.4 autopilot.

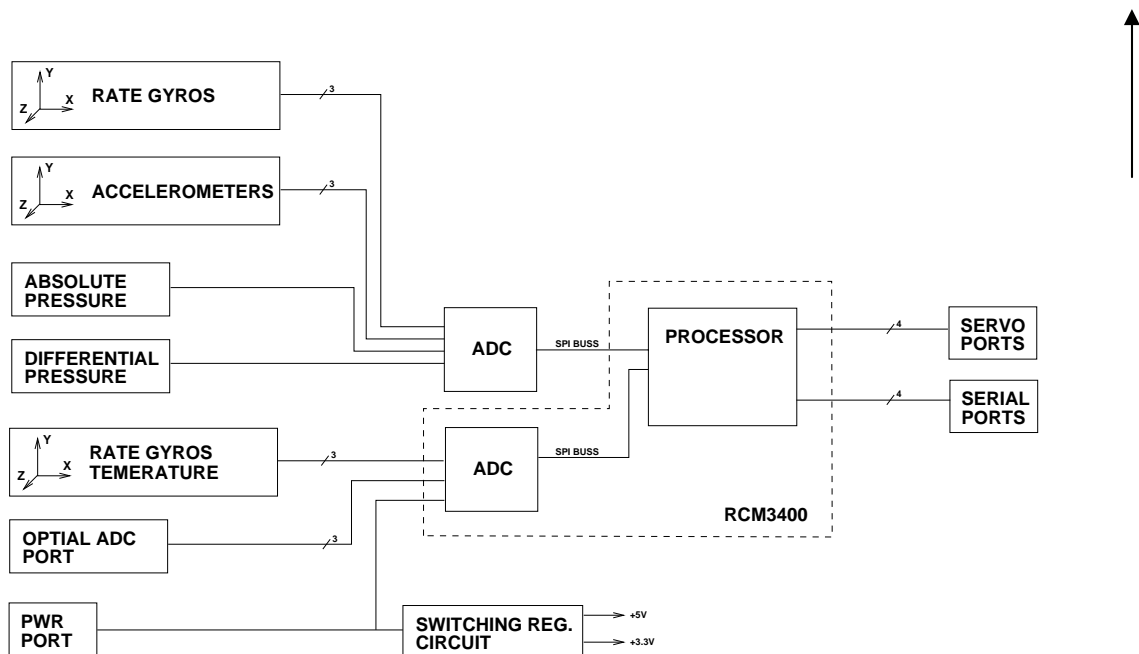

Figure 2 - Kestrel 2.2x block diagram.

Kestrel Autopilot System

Port & LED Locations

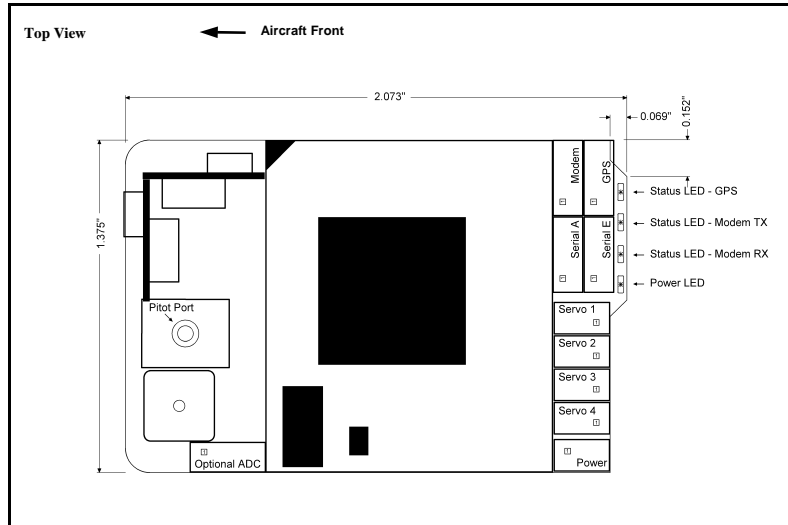

Figure 3 - Port and LED locations on the Kestrel 2.4 autopilot. (2" x 1.37" x .47")

Jumper and Header Locations

Figure 4 shows the location of the serial port power jumpers. These jumpers (0Ω resistors, SMD 0403) connect either the 3.3V or 5V supply to the power pin (pin 2) on each serial port.

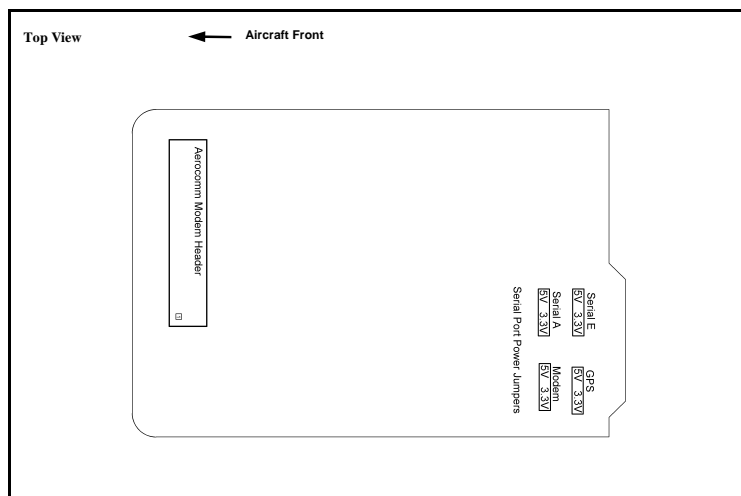

Figure 4 - Jumper and header locations on the Kestrel 2.4 autopilot.

Kestrel Autopilot v2.4

Sensors and Attitude Estimation

- Increased resolution on all sensors (8 x increase)
- Acceleration measurements down to 1 mg
- Roll and pitch estimation corrected for coriolis forces (10% to 25% improved roll and pitch estimates)
- 2axis magnetometer support. Compass heading used to calibrate heading gyro on ground and in low ground speed situations.
- Quicker sensor calibration and improved navigation, path following and altitude hold
- Assist human pilot in speed and altitude mode (display on video)

3-Sensor Temperature Compensation

- 3 temperature sensors combined with 20 point temperature compensation algorithm significantly reduces sensor drift due to temperature changes. This reduces the need for the user to re-calibrate gyros and pressure sensors, aiding in sea or mobile operations.

Wind estimation

- Real-time wind estimation algorithm relies on airspeed and GPS - continually updating estimate with latest wind data. Good to 5% on wind speed and 2% on wind heading.

Auto-trim

- The autopilot can automatically fine tune UAV trim characteristics in the air. Trim values are then saved on the autopilot.

10g Accelerometers

- 10g accelerometers now used vs 2g to better address vibration susceptibility in certain airframe configurations. The Kestrel can also be configured with 2g sensors if desired.

Airframe Types Supported

- V-tail
- Elevon
- Rudder, elevator
- Rudder, elevator, aileron
- Rudder, elevator, flapperon
- Elevator, flapperon
- Ruddervator, aileron

RELATED PARTS

Part Number	Manufacturer	Description	Comments
MOLEX5POS-L10	Procerus Technologies	12-inch cable pigtails (2) for serial connections (GPS).	
JST3POS-L6	Procerus Technologies	3pos, 6-inch pigtail cable for servo and power connections.	4-5 needed per autopilot.
R101-0513+ADAP	Procerus Technologies	Programming Cable with Pigtail	
51021-0500	Molex/Walden	5 pin Molex connector housing. Use w/ serial ports (GPS, modem).	CONN HOUSING 5POS 1.25MM
50058-8000	Molex/Walden	Terminal crimp for Molex connector.	CONN TERM FEMALE 28-32AWG TIN
63811-0200	Molex/Walden	Hand crimp tool for Molex terminal crimp connector.	TOOL HAND CRIMP FOR 1.25MM
63819-0300			
ZHR-3	JST Sales Amer.	3 pin JST connector housing. Used w/ servo ports.	CONN HOUSING ZH 3POS 1.5MM
SZH-003T-P0.5	JST Sales Amer.	Terminal crimp for JST connector.	CONN TERM FEMALE 28-32AWG TIN
WC-490	JST Sales Amer.	Hand crimp tool for JST terminal crimp connector.	TOOL HAND CRIMP ZH 28-32AWG
PRT-CurrSns-1.0	Procerus Technologies	Inductive current sensor – 50 amp	Used to measure current draw on batteries

A list of distributors that carry these parts can be found on the manufacturer's web site.